



V1504

Vertical Platform Lift



OWNER'S MANUAL

(To Be Retained by Owner After Installation
by Authorized Savaria Dealer)

Part No. 000692
25-m05-2011

IMPORTANT

Ensure that only an authorized Savaria Dealer installs and services the V1504 Vertical Platform Lift. Under no circumstances is anyone other than a dealer with Savaria training and authorization to install, adjust, service or modify any mechanical or electrical device on this equipment. Failure to follow this warning can result in safety system compromises or defeat; this can result in serious injury or death. Savaria accepts no liability for property damage, warranty claims or personal injury, including death, in this circumstance.

Passenger safety is the result of countless details in the equipment's design, manufacture, and installation. After installation, reliable operation and continual safe operation requires regular service and inspection at least twice per year, or more frequently where usage, environment, or local jurisdiction requires. As the Owner, you are responsible for ensuring that regular service and inspections occur in a timely manner.

Refer to this manual for specifications, operating instructions and maintenance of the V1504 Vertical Platform Lift.

Upon completion of installation, the dealer must provide you with the following information and ensure it is recorded in this manual. In addition, either the dealer or you must keep any service and/or maintenance records in the Maintenance Record section of this manual.

WARRANTY

Ensure your Savaria Dealer provides you with a copy of the manufacturer's limited parts warranty and documentation relating to any Dealer labour warranty.

FOR OWNER'S RECORDS
Customer Name: _____
Installing Dealer: _____
Dealer's Telephone Number: _____
Date Installed: _____
Serial/Job Number: _____

Table of Contents

TO ENSURE SAFE OPERATION	4
1. DESCRIPTION	5
2. GENERAL SPECIFICATIONS	6
3. OPERATION	8
Operating from the COP Controls	8
Operating from the Landing Station Controls	9
4. SAFETY FEATURES	10
Platform Gate	10
Safety Underpan	10
Door Locks	11
Safety Brake	13
Emergency Stop Buttons	13
Manual Lowering and Battery Lowering System	14
5. MAINTENANCE	15
Maintenance Schedule	16
Maintenance Record	17
Operator Troubleshooting	18

TO ENSURE SAFE OPERATION

To ensure safe operation of this equipment, pay careful attention to the important notes below.

- Read this manual carefully before using the V1504 Vertical Platform Lift.
- To prevent accidents, adhere strictly to the instructions and keep clear of moving parts at all times.
- Follow instructions on all equipment labels at all times. Replace any damaged labels immediately.
- Ensure that only qualified personnel perform maintenance.

1. DESCRIPTION

Figure 1 shows the exterior components of a V1504 (with a Type 1 cab and without an enclosure).

Figure 1

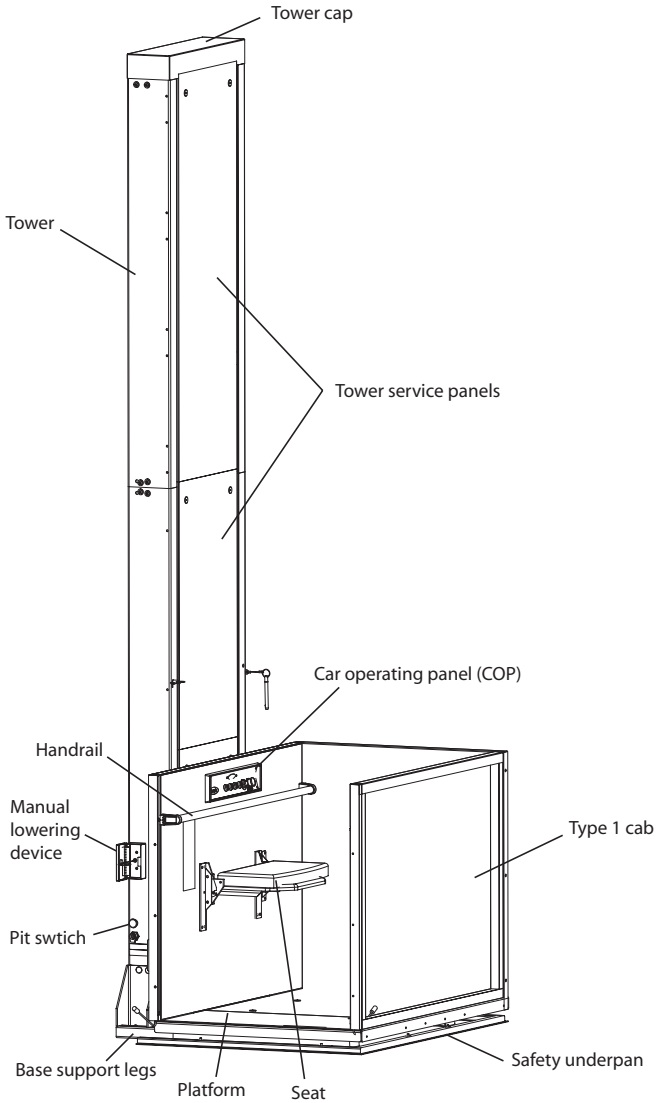

2. GENERAL SPECIFICATIONS

V1504 Specifications

Load capacity	750 lb (340 kg)
Maximum travel	23 ft (7 m)
Travel speed	20 ft/min (0.1 m/s)
Levels serviced	2 (standard), 3, 4
Cab sizes	36" x 48" (914 mm x 1219 mm) 36" x 54" (914 mm x 1371 mm) 36" x 60" (914 mm x 1524 mm)
Side guard panels	42-1/8" (1070 mm) high side guard panels on platform
Cab access	Enter/exit same side (platform Type 1L and 1R) Front/rear access (platform Type 2) 90 degree access (platform Type 3 and 4)
Power supply	120 VAC, 20 A, 60 Hz, single phase
Motor/pump	110 VAC, 1.5 hp (1.12 kW) Gear type hydraulic pump
Control system	Electronic-free relay logic controller
Drive system	2:1 chain hydraulic drive system
Tower	Modular 8 ft (2.4 m) base guide rail assembly Roller guide support
Pit depth requirement	3" (76.2 mm)
Finish	Beige electrostatic powder coat paint on all steel surfaces and vacuumed formed plastics

V1504 Specifications (continued)

Standard features	<p>115 VAC operation (115 VAC up direction; 12 VDC battery down direction)</p> <p>Call/send stations at landings</p> <p>Continuous-pressure type buttons</p> <p>Operating control buttons on platform</p> <p>Automatic battery recharging system (115 VAC)</p> <p>Remote manual lowering device</p> <p>Low-voltage controls</p> <p>Limit switches</p> <p>Handrail</p> <p>Non-skid platform surface</p> <p>No machine room required</p> <p>Emergency stop button</p>
Options	<p>Safety underpan</p> <p>Platform gate with metal insert and electric strike</p> <p>Top landing gate</p> <p>Upper/lower landing door 80" (2032 mm)</p> <p>Fire-rated, flush-mounted landing entrances</p> <p>Folding seat on platform</p> <p>Telephone on platform</p> <p>Custom color</p> <p>Fixed access ramp</p> <p>Public building package</p> <p>Outdoor package</p> <p>Automatic safety ramp on platform (for outdoor model)</p>

3. OPERATION

Operating from the COP Controls

Figure 2 shows a sample car operating panel (COP) for a four-landing installation.

Figure 2

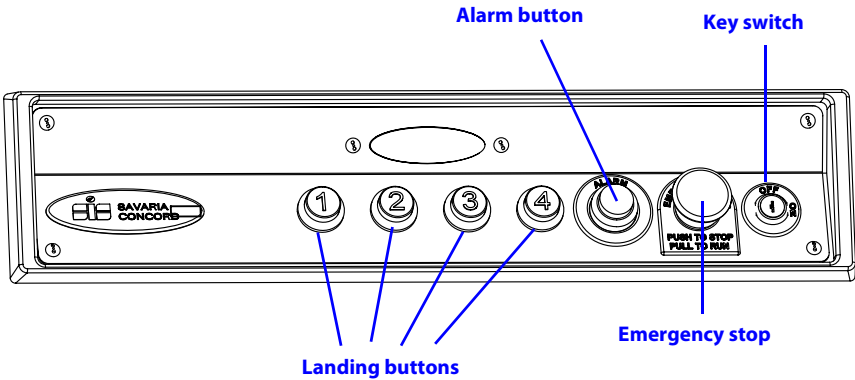

To operate the V1504 from the COP controls:

- 1 Insert the key into the switch (if equipped) and turn it to the ON position to activate the operating buttons.
- 2 Press the appropriate landing button to move the lift to the destination. Note that the V1504 will not move if one of the doors is open.
- 3 When the lift reaches the landing, the door will unlock automatically (for units with mechanical GAL locks). For units with an electric strike, the door will unlock automatically for a few seconds when the lift reaches the landing. If you need to re-open the door after the delay, turn the key (if applicable) to the ON position and press the call button again to unlock the door.
- 4 To prevent unauthorized use of the lift, take the key out when the unit is not in operation.
- 5 Pressing the Emergency Stop button during travel will stop the lift immediately and activate the alarm. The Emergency Stop overrides the landing station controls. Pull the Emergency Stop out to return the lift to normal operation.
- 6 Pressing the Alarm Button during travel will activate the alarm.

Operating from the Landing Station Controls

Figure 3 shows the different types of landing stations (hall calls).

Figure 3

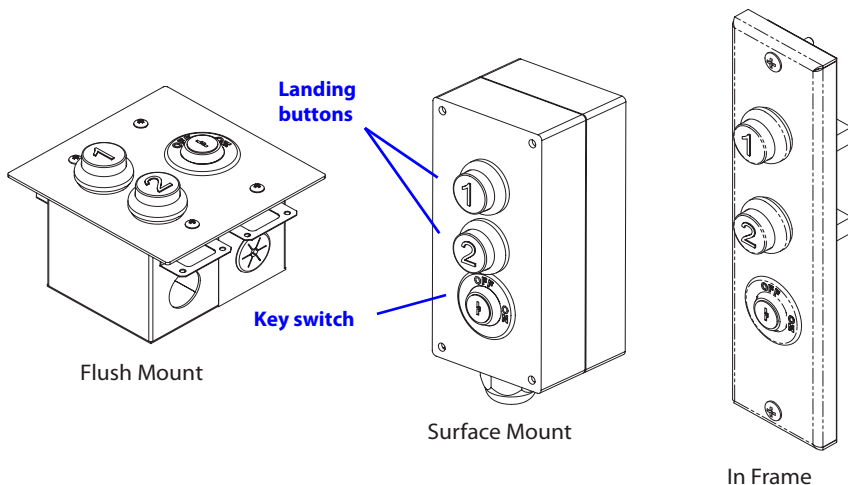

To operate the V1504 from the landing (call/send) station controls:

- 1** Insert the key into the key switch (if equipped) and turn it to the ON position to activate the operating buttons.
- 2** Press the appropriate button to move the lift in the required direction. Note that the V1504 will not move if one of the doors is open.
- 3** When the lift reaches the landing, the door will unlock automatically (for units with mechanical GAL locks). For units with an electric strike, the door will unlock automatically for a few seconds when the lift reaches the landing. If you need to re-open the door after the delay, turn the key on and press the call button again to unlock the door.
- 4** To prevent unauthorized use of the lift, take the key out when the unit is not in operation.

4. SAFETY FEATURES

Platform Gate

The platform gate (shown in Figure 4) prevents the passenger from falling off. This safety feature is optional for residential use and required for public applications.

Figure 4

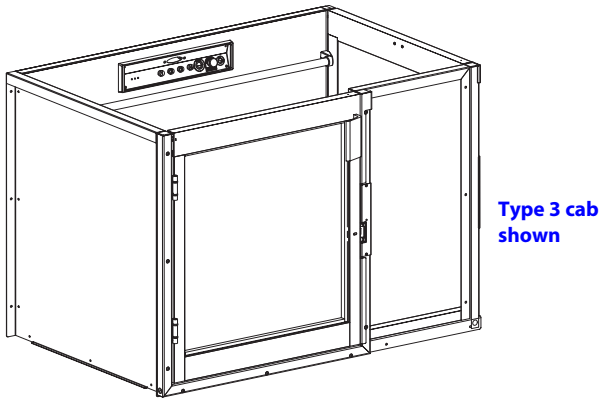

Safety Underpan

The safety underpan (shown in Figure 5) is located under the platform. The underpan has sensors that detect any obstacles and stop the downward travel of the lift.

Figure 5

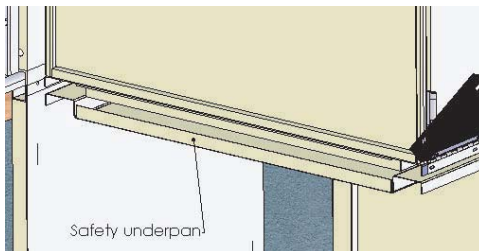

Door Locks

The door lock keeps the door locked when the platform is moving and not at a landing.

- WR-500 lock
- GAL lock
- Electric strike

NOTE

Keys are for emergency use only and should always be kept in a safe place for use by trained personnel only.

Emergency Door Opening

For units with a **WR-500 lock**, the door can be opened manually using the emergency key provided (Figure 6).

Insert the key into the lock and turn it a half turn clockwise to unlock the door. Pull the door open and then turn the key a half turn counter-clockwise to remove it from the lock.

Figure 6

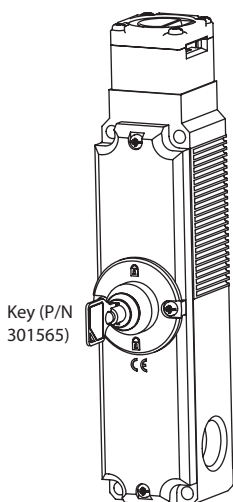

For units with a **strike** on the door, the door can be opened manually using a 1/4" Allen key inserted through the hole in the front of the door (Figure 7).

Figure 7

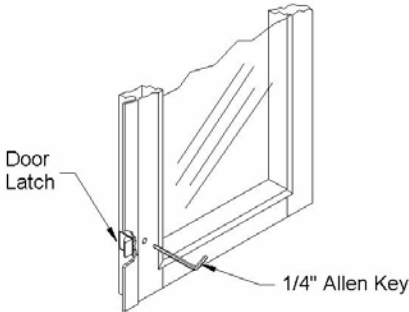

For units with a **GAL lock**, the door can be opened manually using a special key inserted into the round pin on the front of the lock (Figure 8).

Figure 8

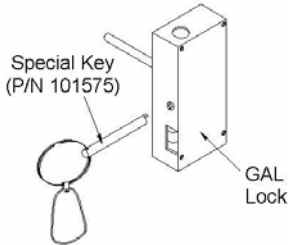

Safety Brake

The safety brake stops the platform in the event of chain failure.

When the platform is in operation, the chain tension keeps the brake mechanism up (Figure 9) so that the brake's cam doesn't interfere with the tower track.

If a chain failure occurs, the brake mechanism comes down (Figure 9) and the brake cam stops the platform.

Figure 9

Safety brake in operating position

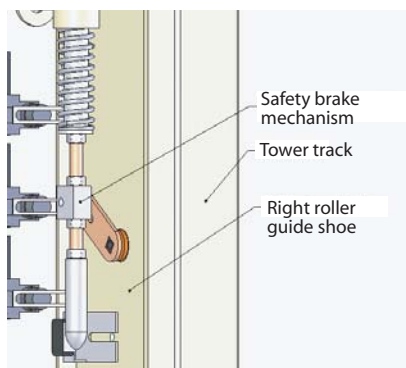

Safety brake in down position

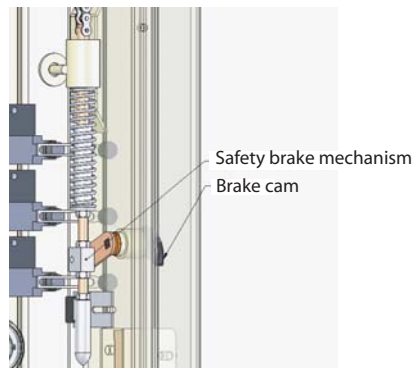

Emergency Stop Buttons

Pressing one of the red Emergency Stop buttons during travel will stop the lift immediately and activate the alarm. The Emergency Stop overrides the landing (call/send) stations. Pull the Emergency Stop out to return the lift to normal operation.

Manual Lowering and Battery Lowering System

If a power failure occurs, a battery lowering system will bring the lift to the bottom level. If the battery fails while operating, there is also a manual lowering device that will bring the lift to the lower level.

For units with a 120 VAC pump, the manual lowering box (Figure 10) is located on the side of the V1504. When you pull on the steel cable located inside the manual lowering box, the platform descends to ground level.

Figure 10

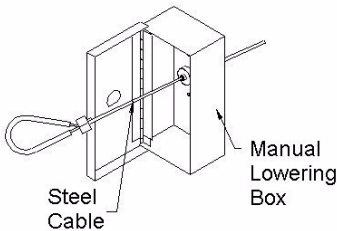

NOTE

This mechanism is for emergency use only.

5. MAINTENANCE

NOTE

The owner can perform the 2-month inspections, but the 6-month inspections **must** be performed by a Qualified Technician. Contact your Authorized Dealer.



DANGER

Always use the shoring pins when working under the lift. For lower travel heights, insert the pins into the lower holes (at 600 mm).

Figure 11

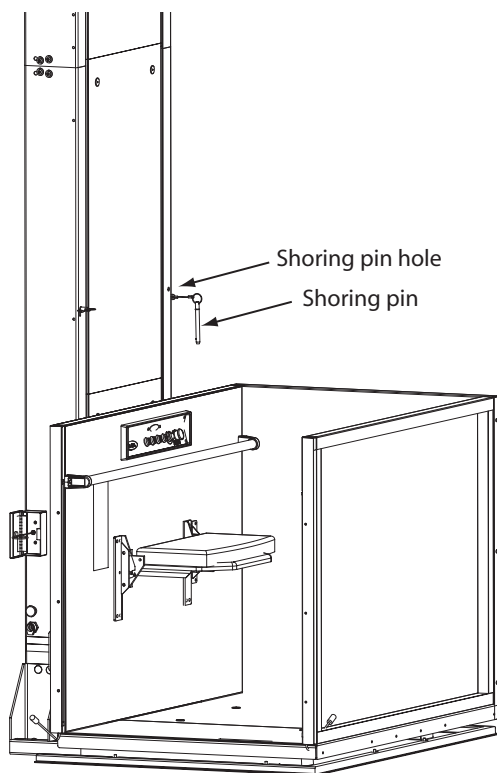

Maintenance Schedule

Verification by owner	Frequency
For units with a door strike, the lift should not move if any door is not closed and locked.	Every 2 months
<p>For units with a GAL lock, the lift should not move if any door is not closed.</p> <p>The lift should not move beyond the door zone (usually less than four inches away from the landing in either direction) if the door is not locked.</p>	Every 2 months
<p>Verify the underpan is working.</p> <p>Be sure to insert the shoring pins.</p>	Every 2 months
Verification by technician ONLY	Frequency
<p>Check the suspension system:</p> <ul style="list-style-type: none"> • Chains • Connecting links • Chain pulleys and shafts • Parts holding the chains on the roller supports • Chain tensioners on the rail (they should be tight) • Cylinder head (cotter pins, cracks, welds) • Up relays - if you have two up relays (solenoids or contactors), make sure one of them is not stuck in the activated position. Use a multimeter to verify that every N.O. contact is open when the relays are not being activated. 	Every 6 months
Check the safety brake.	Every 6 months
Check for oil leaks.	Every 6 months
Check the rollers.	Every 6 months

Maintenance Record

Date	Time	Reason for Call	Comments	Dealer

Operator Troubleshooting

The following table lists potential problems and their possible solutions.

If the problem persists, contact your Authorized Dealer.

Potential Problem	Possible Solution
Platform goes up but does not come down	Check the underpan sensor. Pull down on the underpan to ensure the pan is not stuck in the activated position.
Platform comes down but does not go up	Check the power supply (breaker, cord, battery, etc.).
Platform does not move	Check that the key is ON (if applicable). Check that the doors are closed. Check to see if the Emergency Stop is pushed in; it should be pulled out for normal operation. If the platform is at the top landing, check the underpan sensor as described above.

Authorized Savaria Dealer

V1504 Vertical Platform Lift OWNER'S MANUAL

Part No. 000692
Copyright © 2011

Savaria Corporation
Elevators and Lifts
www.savaria.com

Sales
107 Alfred Kuehne Blvd.
Brampton, Ontario, L6T 4K3, Canada
Tel: (905) 791-5555
Fax: (905) 791-2222
Toll Free: 1-800-661-5112

