

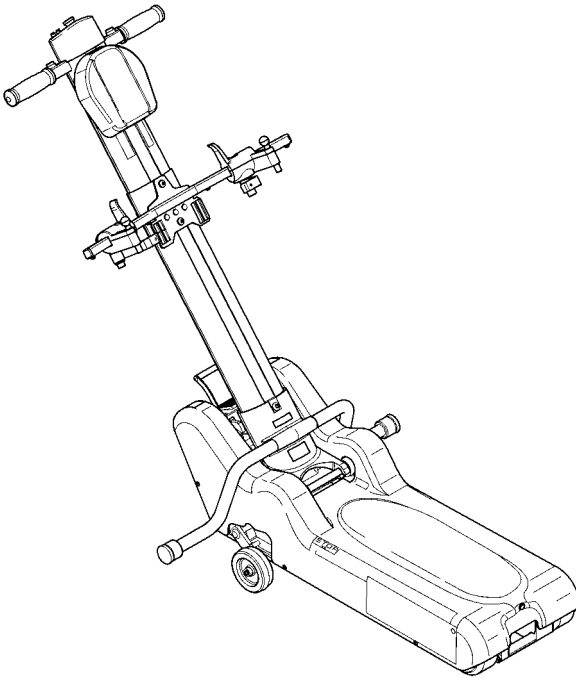

Roby

Powered Stair Climber



OWNER'S MANUAL

(To Be Retained by Owner)

Savaria Corporation
Part No. 000686
01-m06-2011

IMPORTANT

Ensure that only an authorized Savaria DEALER services the Roby Powered Stair Climber. Under no circumstances is anyone other than a Dealer with Savaria training and authorization to adjust, service or modify any mechanical or electrical device on this machine. Failure to follow this warning can result in safety system compromises or defeat; this can result in serious injury or death. Savaria Corporation accepts no liability for property damage, warranty claims or personal injury, including death, in this circumstance.

Passenger safety is the result of countless details in the machine’s design and manufacture. Reliable operation and continual safe operation requires regular inspection and maintenance as outlined in this manual, or more frequently where usage, environment, or local jurisdiction requires. As the Owner, you are responsible for ensuring that regular inspections and maintenance occur in a timely manner.

Refer to this manual for component description, setup, operating instructions, and maintenance of the Roby Powered Stair Climber.

The dealer must provide you with the following information and ensure it is recorded in this manual. In addition, either the dealer or yourself must keep any service and/or maintenance records in the Maintenance Record section of this manual.

WARRANTY

Ensure your Savaria Dealer provides you with a copy of the manufacturer’s limited parts warranty and documentation relating to any Dealer labour warranty.

FOR OWNER’S RECORDS

Customer Name: _____

Installing Dealer: _____

Dealer’s Telephone Number: _____

Date Installed: _____

Serial/Job Number: _____

Table of Contents

1. DESCRIPTION	6
Chassis	6
Steering Bar	8
Control Panel	9
Battery Charger	9
Mechanical Safety Features	10
Electrical Safety Features	10
Warning and Caution Plates	10
Work Position	11
2. SPECIFICATIONS	12
Dimensions	14
3. PROPER AND IMPROPER USE	15
Proper Use	15
Improper Use	16
4. TRANSPORT	17
Handling	17
Storage	17
Center of Mass	18
5. SETUP	19
Unpacking	19
Disposal of Packing Material	19
Preliminary Checks	19
Environmental Conditions	20
Electrical Connection	20
Battery Charger Data	20
6. OPERATION	21
Assembling the Steering Bar Post	21
Steering Bar Release	23
Attaching a Wheelchair to the Stair Climber	24
Travel Preparation	28
Manual Operation on a Level Floor	28
Stair Gradient Check	29
Headrest Adjustment	29
Operation on a Staircase	30
Emergency Stop and Passenger Recovery	37
Passenger Release	38

7. REVERSING THE SAFETY COUPLINGS39

8. MAINTENANCE42

 Maintenance Record43

 Periodic Cleaning44

 Charging the Battery45

 Unit Does Not Start or Move46

 Disposal of Parts and Materials46

9. DETAILED DRAWINGS47

TO ENSURE SAFE OPERATION

To ensure safe operation of this unit, pay careful attention to the important notes below.



This symbol accompanies a number of essential safety instructions. Compliance with these instructions does not release the owner from their obligation to follow all additional safety regulations.

IMPORTANT

- Read this manual carefully before using the Roby.
- To prevent accidents, adhere strictly to the instructions and keep clear of moving parts at all times.
- Follow instructions on all Roby labels at all times. Replace any damaged labels immediately.
- In the event of unusual performance, contact a skilled technician.
- Ensure that only qualified personnel perform Roby maintenance.
- The following symbols are used to ensure that only qualified personnel perform the activities in this manual:
 - Trained operator
 - OC Trained operator with specific skill
 - OS Skilled operator authorized by the manufacturer
- The Roby is intended for use by an adult that understands its proper operation as set out in this manual.

1. DESCRIPTION

Chassis

The chassis (Figure 1/a) is a light skeleton type that includes plastic protection and contains the following components:

- Motor
- Transmission gears
- Tracks
- Wheels for fast manual movement on the floor
- Electrical
- Battery

Figure 1

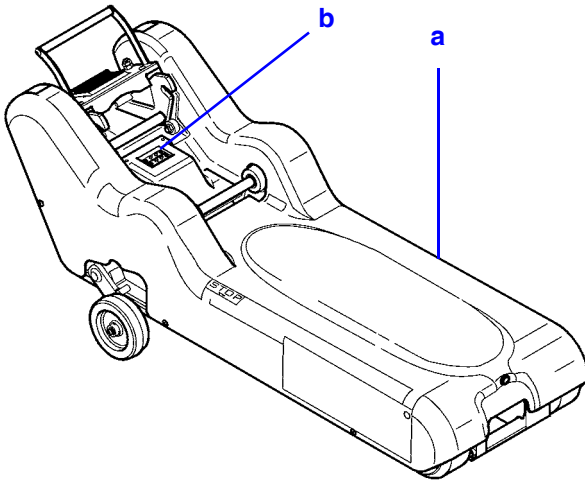

The control panel on the chassis includes the following components:

- Steering bar release lever (Figure 2/a)
- Battery charger plug (Figure 2/b)
- Bipolar electrical connector for the controls on the steering bar (Figure 1/b)
- Pushbutton for base forward/backward control (Figure 2/c)

Figure 2

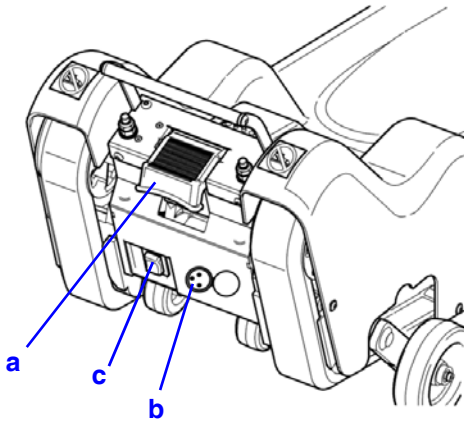

Steering Bar

The steering bar (Figure 3/a) includes wheelchair clamping and control functions. The main controls for the stair climber are on the steering bar and include the following components:

- Wheelchair safety clamp assembly (Figure 3/c)
- Wheelchair crossbar clamp with height adjustable lock (Figure 3/d)
- Manual auxiliary wheels cross-member (Figure 3/e)
- Adjustable headrest (Figure 3/b)
- Bipolar chassis electrical connector (Figure 3/f)

Figure 3

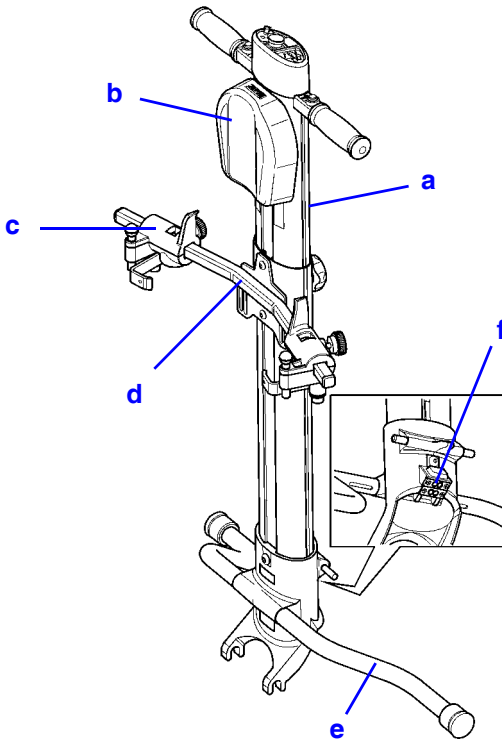

Control Panel

The control panel is located between the two handles (Figure 4/f) and includes the following components:

- Ascend/descend pushbuttons (Figure 4/a)
- Emergency STOP button (red head) (Figure 4/b)
- Gradient indicator (Figure 4/c)
- Battery charge condition indicator LED (Figure 4/d)
- "ON/OFF" key (Figure 4/e)

Figure 4

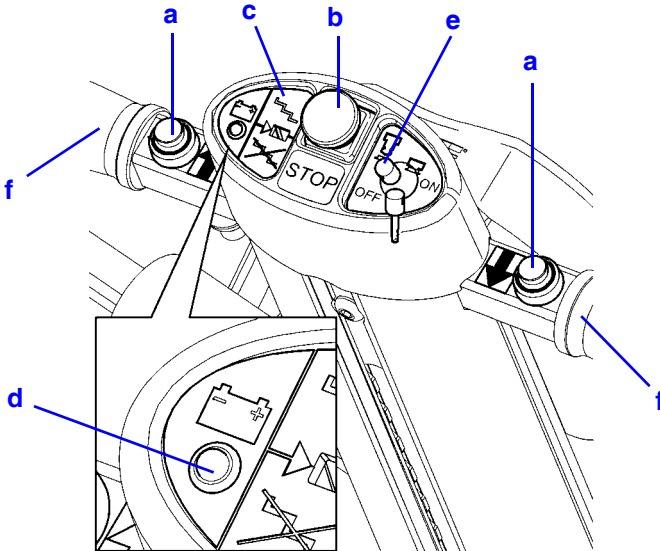

Battery Charger

The battery charger recharges the battery after stair climber use and maintains the battery charge condition when the Roby is not being used.

Mechanical Safety Features

Wheelchair clamping to the steering bar

- Safety clamp piston (Figure 5/a)
- Crossbar vertical height knob (Figure 5/c)
- Safety clamp locking handwheel (Figure 5/b)

Figure 5

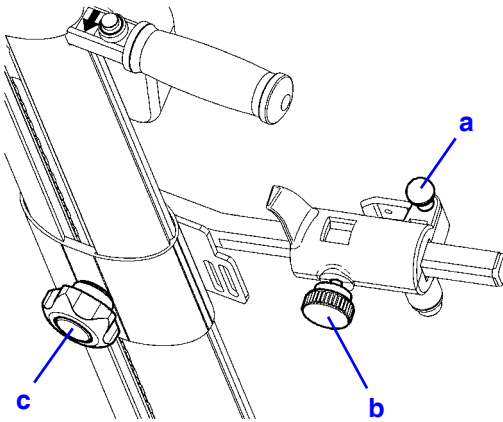

Electrical Safety Features

The optical indicator displays the maximum gradient (Figure 4/c).

Warning and Caution Plates

The Roby includes the following warning and cautions plates that are visible during operation:

- Fasten safety belts
- Grasp steering bar with both hands while operating
- Never leave the Roby loaded
- Wheelchair attachment instructions

Work Position

**WARNING**

The driver must stand behind the stair climber and firmly hold the handle bars (Figure 4/f) while operating the Roby.

2. SPECIFICATIONS

Traction Gear	
Irreversible worm screw reduction gear	Ratio 1/50
Toothed belt with rubber tracks	HTD-8M
Drive pulley	z=40
Backstand mechanical system	
Wheels for transfer on floor	No. 4 wheels on ball bearings
Performance	
Running direction	Forward/backward
Speed (up/down)	16.4 feet/min (5 metres/min)
Capacity	1 person with wheelchair
Rated load	285 lb (130 kg)
Maximum stair gradient and rise	See Figure 7
Environmental Conditions	
Temperature	32° F to 113° F (0° C to 45° C)
Humidity	Maximum 90%
Noise	Less than 70 db
Vibration	<p>The Roby can induce passenger vibration and sound by the following means:</p> <ul style="list-style-type: none"> - Low frequency and moderate acceleration - Brief exposure cycles for the exposed persons
Overall Dimensions	
Machine chassis	See Figure 6
Steering bar	See Figure 6

Weight	
Machine body	81 lb (37 kg)
Steering bar	22 lb (10 kg)
Electrical Installation	
DC brushless motor	24V
Electrical input	25A
Battery charger	100-240 VAC, 50-60 Hz, 3A
Sealed battery with electrolyte	2x12 V 12 Ah
Battery recharge time	8 hours if battery is totally exhausted
Fuse	T3A250
Controls	
Timed start pushbutton (forward/backward)	1 second delay
Emergency STOP button	On steering bar control panel
Signals	
Battery charge condition indicator LED	On steering bar control panel
Gradient indicator	On steering bar control panel

Dimensions

Machine dimensions are shown in Figure 6 below.

Figure 6

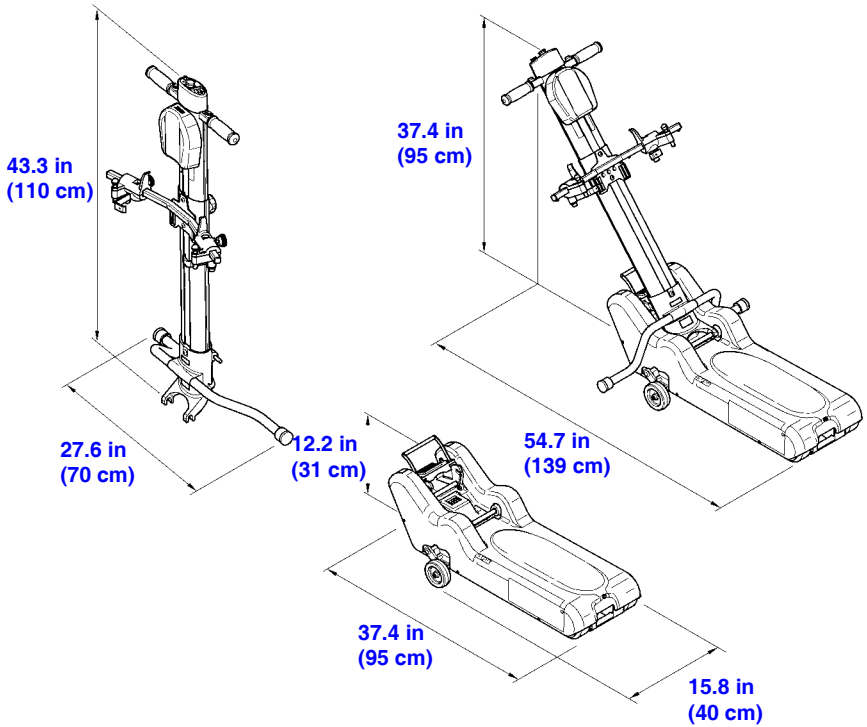

3. PROPER AND IMPROPER USE

Proper Use

The Roby stair climber is designed for the transport of persons in manual wheelchairs on staircases. Proper use of the Roby stair climber includes the features below.

Environment	Indoor/outdoor
Steps	Parallel, without coatings
Gradient	Maximum 35° (Figure 7)
Step riser height	Minimum 3.94 in (10 cm) to maximum 7.09 in (18 cm); Figure 7
Step nose radius	From 0 to maximum 0.79 in (0 to 2 cm); Figure 7
Attendant	Always present and with the following characteristics: an adult who understands how to operate the equipment and who understands the maintenance instructions.

Figure 7

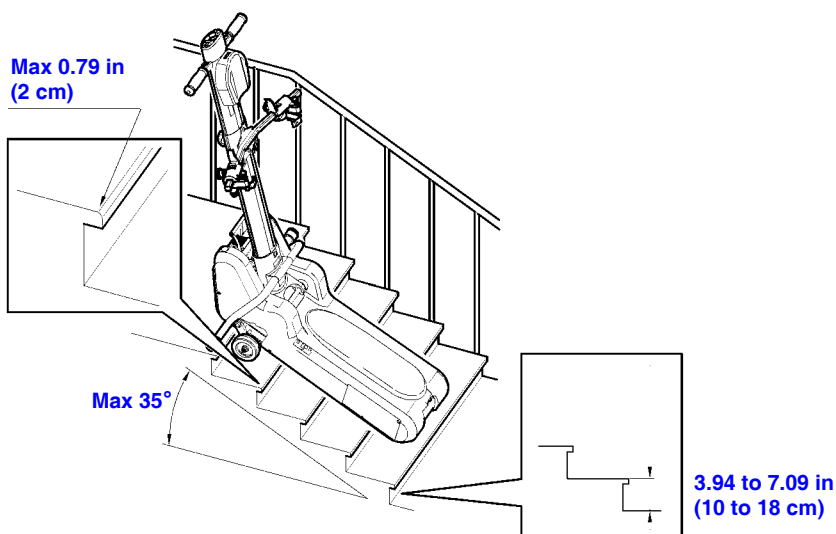

Improper Use

Improper Use	Result
Use on staircases with gradient over 35°	Instability, tracks skidding
Use on steps with riser height over 7.09 in (18 cm)	Instability, tracks skidding
Use on steps with riser height less than 3.94 in (10 cm)	Tracks skidding
Use on steps with a step nose radius greater than 0.79 in (2 cm)	Tracks skidding
Guided by an untrained or unqualified operator	Instability
Transport of electrically powered wheelchairs	Unsafe
Transport of things or people not seated on the wheelchair	Unsafe
Use on steps in the presence of water, snow or ice	Instability, tracks skidding
Use on wet surfaces or in the rain	Electric installation failure
Use on staircases without parallel steps	Instability, lateral tilting



Never make modifications to the stair climber. Use the stair climber only as intended.

4. TRANSPORT

Handling

A dismantled Roby can be transported manually for short trips or for load/unload operations. Transport the chassis using the handles at both ends (Figure 8/a and b), using two people to lift the chassis.

Figure 8

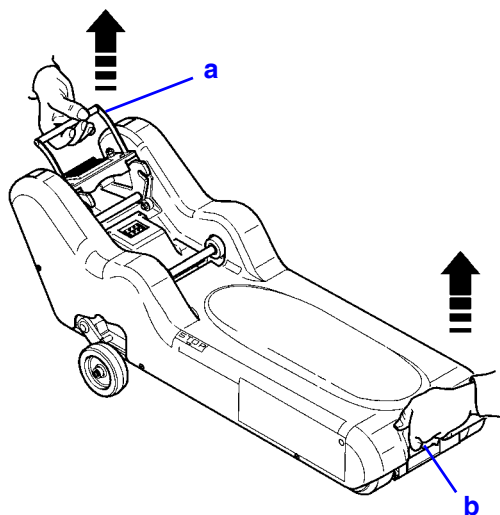

Chassis weight with battery

- 81 lb (37 kg)

Steering bar weight

- 22 lb (10 kg)

Storage

- 1 Place the machine in a dry room.
- 2 Cover the machine.
- 3 Store indoors only.
- 4 Connect the battery charger to an electrical source.

Center of Mass

The centre of mass is in the lock position between the steering bar and the chassis (Figure 9/a).

Figure 9

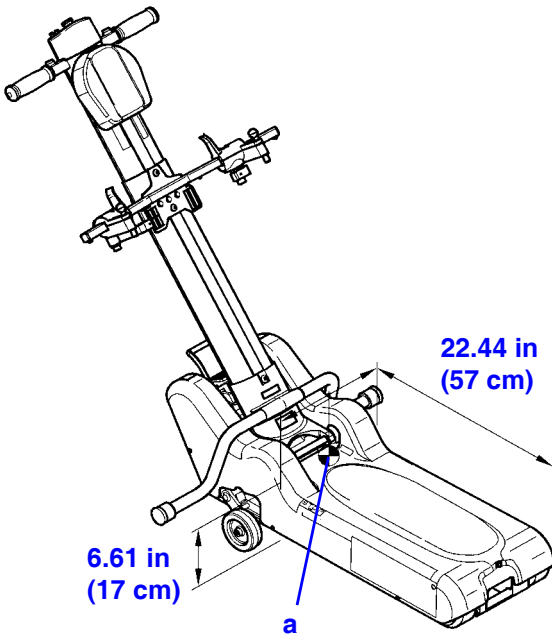

5. SETUP

Unpacking

- 1 Unpack the machine in a warm, dry area.
- 2 Cut the protective film with a knife; do not break it and consequently scratch or damage the finish.
- 3 Clean the outside of the Roby. Remove any and all residual packaging and dust.

Disposal of Packing Material

Dispose of all packing material at a local facility.

Preliminary Checks

Perform the following checks before using the Roby.

Competence Level Required: OS - Skilled Operator

Check Machine Components

- Check the steering bar safety clamp (Figure 3/c).
- Check the steering bar knobs (Figure 5/b).
- Check the safety belt (Figure 20).
- Check the clamping/releasing assembly.

Check Controls

- Check that the motion controls are functioning as intended.
- Check the control timing.
- Check the emergency STOP button (Figure 4/b).

Check Signals

- Check the battery charger signal (Figure 4/d).
- Check the gradient visual signal (Figure 4/c).

Environmental Conditions

- Temperature: 32°F to 113° F (0°C to 45°C)
- Humidity: Max. 90%

Electrical Connection

- Connect the battery charger to the Roby (Figure 2/b) and plug the charger cord into a wall outlet.

Battery Charger Data

- Voltage rating (IN): 120 VAC
- Frequency (IN): 60 Hz
- Voltage rating (OUT): 24V DC, 4A

6. OPERATION

Assembling the Steering Bar Post

- 1 Insert the post (Figure 10/a) at the u-hooks onto the circular cross-member (Figure 10/b) on the base.

Figure 10

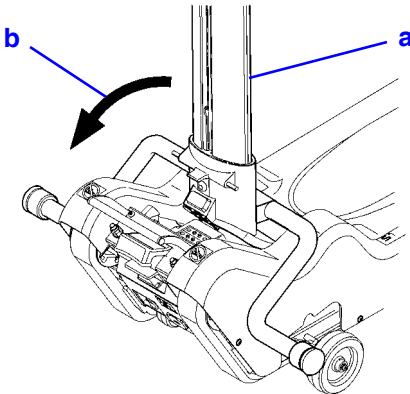

- 2 Incline the steering bar post (Figure 10/a) as shown by the arrow (Figure 10/b) until it locks into the base.
- 3 Once the steering bar is locked (Figure 11/a), push the red plastic safety protective cover down onto the post release lever (Figure 11/b).



WARNING

Ensure that the Roby safety protective cover is in its proper position. In this configuration, the electrical contact outlet is engaged and the steering bar is locked in the work position. If the safety protective cover is not in its proper position, the Roby does not run.

Figure 11

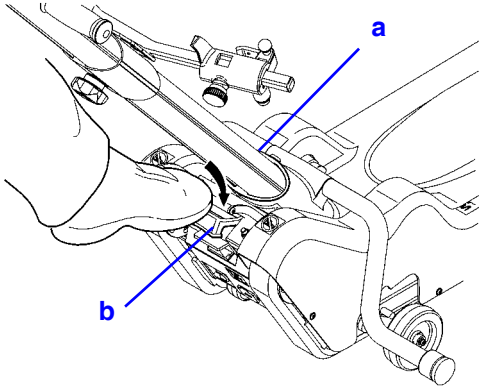

Steering Bar Release

To release the steering bar (Figure 12/a), lift the red plastic safety protective cover (Figure 12/b). Release the red pedal (Figure 13/b) and push the steering bar (Figure 13/a) forward as shown by the arrow (Figure 13/c).

Figure 12

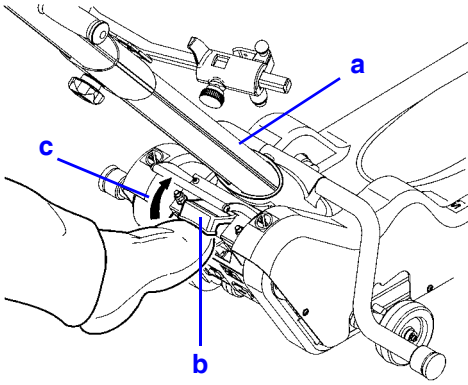
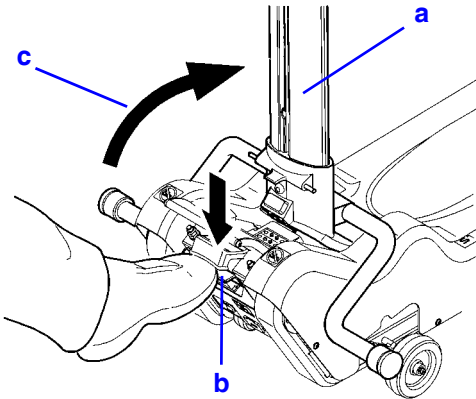

Figure 13



Attaching a Wheelchair to the Stair Climber

- 1 Lock the wheelchair brake. Insert the key (Figure 14/a) into the steering bar control panel key slot (Figure 14/b) and release the emergency STOP button.

Figure 14

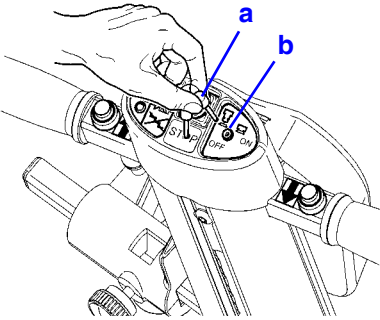

- 2 Press either the ascend or descend button on the steering bar and move the stair climber under the wheelchair (Figure 15/a).

Figure 15

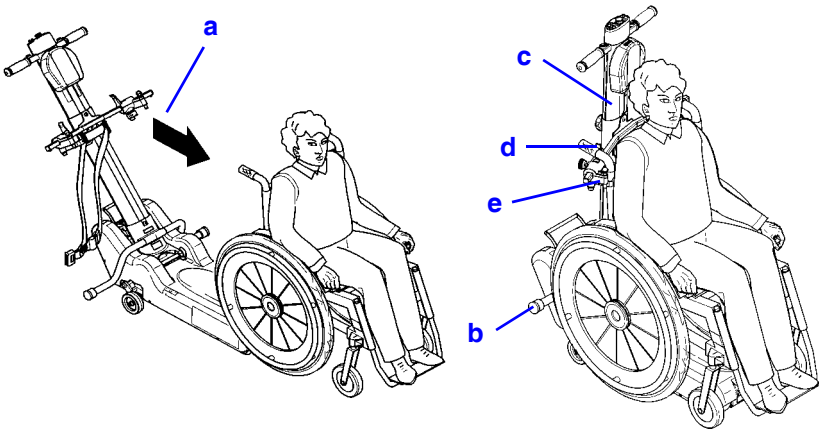

- 3 To release the steering bar post (Figure 12/a), lift the red plastic safety protective cover (Figure 12/b), release the red pedal (Figure 13/b), and push the steering bar (Figure 13/a) forward as shown by the arrow (Figure 13/c).
- 4 Push the post towards the wheelchair.
- 5 While holding the crossbar (Figure 16/e), unscrew (Figure 16/b) the vertical height knob (Figure 16/a). Push the metallic central pushbutton (Figure 16/c) and slide the wheelchair clamp assembly (Figure 16/d) up/down on the post until the crossbar is just under the vertical height of the wheelchair handgrips (Figure 15).

Figure 16

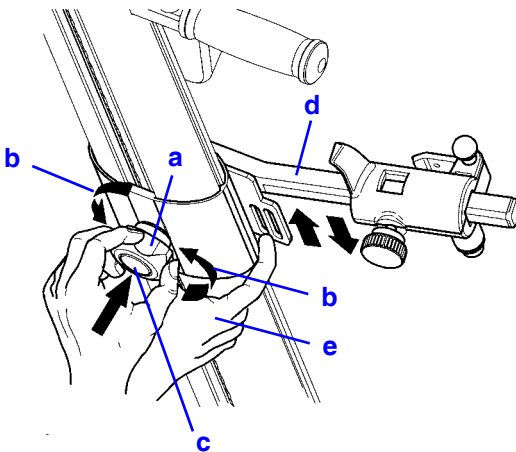

- 6 Loosen each safety clamp assembly (Figure 17/a) by turning the locking handwheel counter-clockwise (Figure 17/b). Slide the safety clamp assembly horizontally (Figure 17/c) until snug against the wheelchair vertical back support posts.

Figure 17

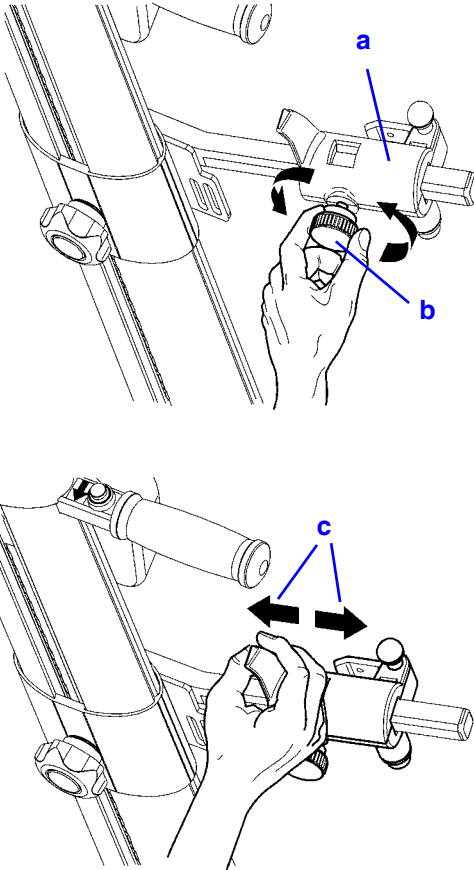

- 7 Lift each safety clamp piston (Figure 18/a), swing each metal hook to the wheelchair arm (Figure 18/b), and release the safety clamp piston to ensure each hook can't open. Tighten each safety clamp locking handwheel (Figure 17/b).

NOTE

Do not clamp handles or other objects that might slip off the wheelchair.

Figure 18

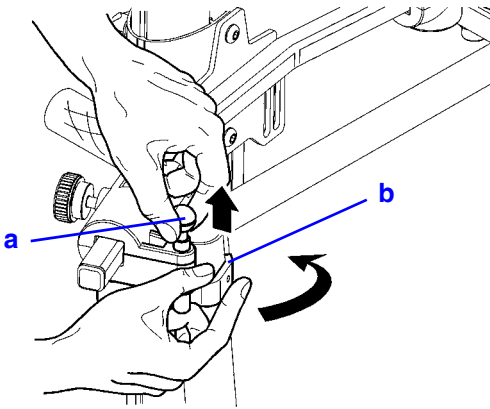

- 8 Move the steering bar post back to the hooked position (Figure 10/b) and hook the post to the base.
- 9 Use the base for leverage, if required. Push the red plastic safety protective cover down onto the post release lever (Figure 11/b) by foot.
- 10 The machine activates and the green LED on the control panel lights. The wheelchair is properly attached and anchored to the stair climber.
- 11 Press downward on the steering bar to activate the manual auxiliary wheels. Maneuver the Roby to the leading edge of either stair-flight to perform a descent or an ascent (see Figure 27 and 30).

Travel Preparation

Battery

Check the battery charge once the Roby is fully assembled. First activate the machine without a passenger before using the machine on stairs. Note that using the machine when the battery charge condition indicator LED is blinking can cause battery damage.

Signals



Always check the control panel on the steering bar for a tipping signal before proceeding onto a staircase.

If the visual signal is not functioning, DO NOT USE the stair climber! Call your Authorized Dealer.

Emergency STOP

Check the operation of the emergency **STOP** button (red button on the control panel).

- Press the button; the controls should be off-line.
- Reset the button by pulling it out.



If the emergency STOP button does not function, DO NOT USE the stair climber! Contact your Authorized Dealer.

Manual Operation on a Level Floor

To move or turn in manual mode:

- 1 Using the steering bar as a lever, raise the front side of the Roby to utilize the manual auxiliary wheels.
- 2 Move the Roby towards you and turn in the desired direction. Proceed forward in the desired direction.

Stair Gradient Check

Always perform the stair gradient check on unfamiliar stairs:

- 1 Check that the step rise is not greater than 7.09 in (18 cm) as shown in Figure 7.
- 2 In manual mode, without a passenger, approach the first stage of the stairs to travel. Press the ascend/descend pushbutton (Figure 4/a), advance on a section of the stairs and release the pushbutton. Ensure the gradient indicator (Figure 4/c) on the steering bar is green (gradient under 35°). If the indicator is red (gradient above 35°), it is not possible to travel on that staircase.

Headrest Adjustment

To adjust the headrest (Figure 19/a), remove it and adjust as required using the two Velcro strips (Figure 19/b).

Figure 19

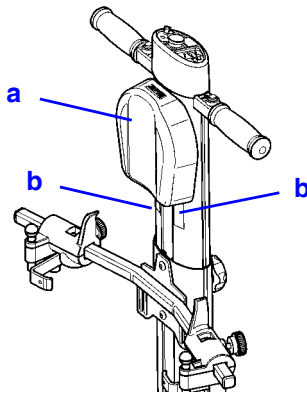

Operation on a Staircase



WARNING

Always fasten the seat belt before mounting a flight of stairs.

Hold the steering bar firmly with both hands, whether on stairs or on a level floor.

Do not move the stair climber with a passenger on board before completing all operations described in the section “Attaching a Wheelchair to the Stair Climber”.

Never release your grip on the handle bars while carrying a passenger.

The person who uses the stair climber determines the stability of the Roby. To avoid unstable conditions, adhere to the following guidelines at all times.

Always place the Roby so that the transported passenger’s shoulders are towards the ascent side. If during operation the stair climber does not stop when you release the ascend/descend pushbutton, press the red emergency **STOP** button on the steering bar control panel. Refer to the emergency stop instructions in the section “Emergency STOP”.

Descent

- 1 With the wheelchair properly attached to the stair climber and the green light lit on the steering bar control panel, put pressure on the steering bar (Figure 20/b) such that the nose of the Roby rises (Figure 20/d) and the manual auxiliary wheels activate (Figure 20/c). Move the machine to the edge of the first stair of the flight (Figure 20/a).
 - For staircases with one flight, move the Roby to the center of the staircase, front to back, with the front parallel with the step.
 - For staircases with more than one flight, move the Roby to the center of the staircase, front to back, with the front parallel with the step. To help maneuver around the base of each flight, keep the Roby as close to the outer edge (wall side) as possible.



WARNING

Ensure the stair climber is perpendicular to the steps. Do not attempt to travel on staircases diagonally.

Figure 20

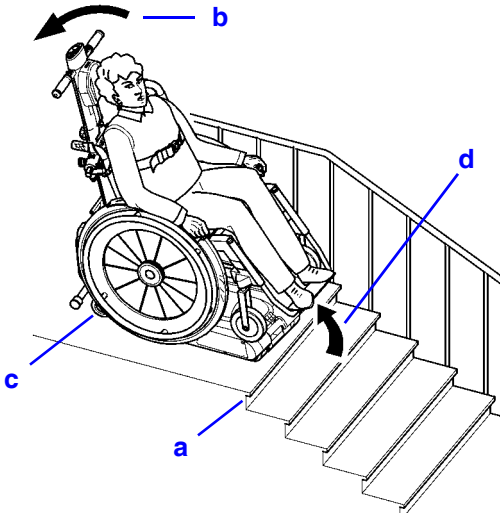

- Press the **descend** pushbutton until the **STOP** sticker (on the base of the Roby) is parallel (Figure 21/a) to the edge of the first stair (Figure 21/b).

Figure 21

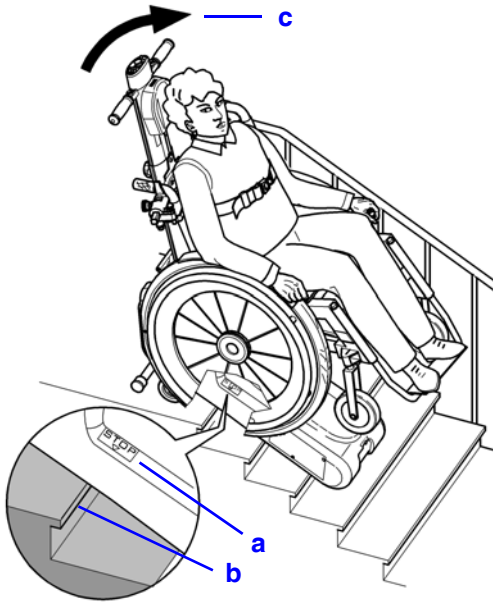

- Raise the steering bar (Figure 21/c) until the tracks touch the lower step. Press the **descend** pushbutton (there is a one second delay) until the Roby contacts the first stair. Keep the **descend** pushbutton engaged and travel down the stairs while holding the steering bar firmly with both hands.



WARNING

The small blocks on the tracks can slide on the step edge during operation and when at a standstill. Sliding can cause the stair climber to tip over forward. Use caution when operating. Hold the steering bar firmly with both hands and do not release your grip.

- When the Roby reaches the end of a flight, it automatically levels out.

- 5 If this is your final destination, guide the Roby away from the flight of stairs and release the wheelchair as described in the section "Passenger Release".
- 6 If there is another flight of stairs to descend, follow this step. Push and turn the Roby and place it on the edge of the first stair of the next flight (see Figure 22). Press the **descend** pushbutton until the **STOP** sticker (on the base of the Roby) is parallel (Figure 21/a) to the edge of the first stair (Figure 21/b).
- 7 Raise the steering bar (Figure 21/c) until the tracks touch the lower step. Press the **descend** pushbutton and descend to the next flight or, if the final destination is reached, release the wheelchair.

Figure 22

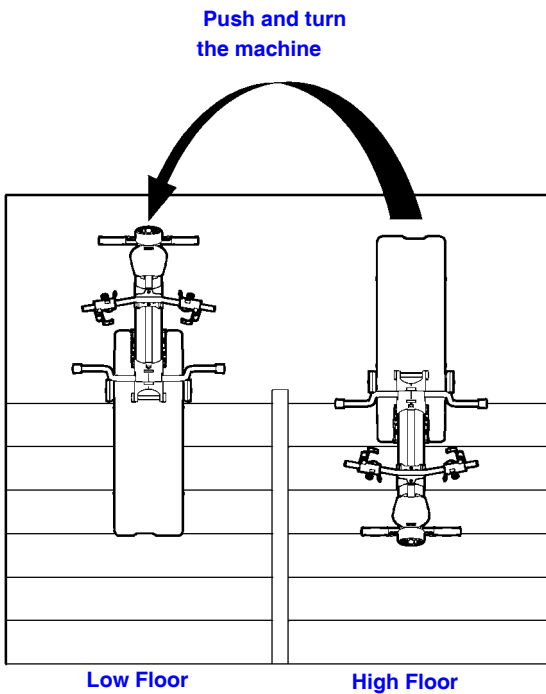

Ascent

- 1 With the wheelchair properly attached to the stair climber and the green light lit on the steering bar control panel, put pressure on the steering bar (Figure 23/b) such that the nose of the Roby rises and the manual auxiliary wheels activate. Guide the machine to the edge of the first stair (Figure 23/a).
 - If you are traveling just one flight, position the Roby in the middle of the flight.
 - If there is more than one flight of stairs, travel as near to the handrail as possible or near the wall that delimits the stairwell. This position makes manual operation on landings easier.



Ensure the stair climber is perpendicular to the steps. Do not attempt to travel on staircases diagonally.

Figure 23

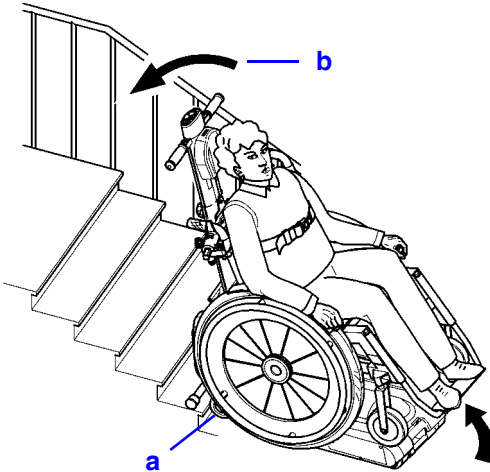

- Press the **ascend** pushbutton while holding the steering bar firmly with both hands. Travel up the flight until the Roby reaches the last stair.



The small blocks on the tracks can slide on the step edge during operation and when at a standstill. Sliding can cause the stair climber to tip over forward. Use caution when operating. Hold the steering bar firmly with both hands and do not release your grip.

- At the last stair, release the **ascend** pushbutton to stop the Roby when the **STOP** sticker on the base is parallel with the stair (Figure 24/a and b). Put pressure on the steering bar (Figure 24/c) such that the nose of the Roby rises.

Figure 24

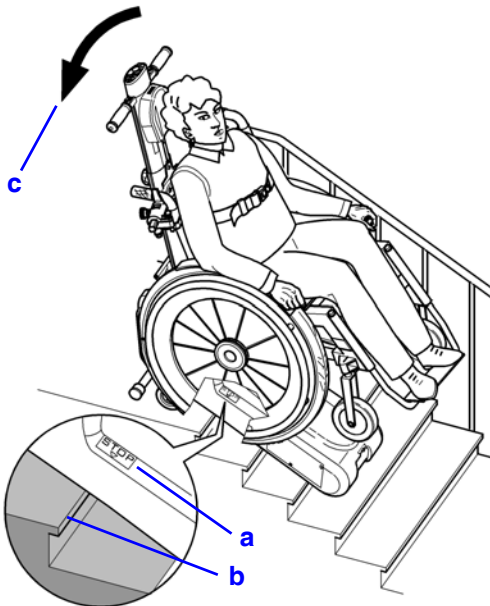

- 4 At the top of the flight of stairs, and once the machine is level, press downward on the steering bar again to activate the manual auxiliary wheels.
- 5 If this is your final destination, guide the Roby away from the flight of stairs and release the wheelchair as described in the section "Passenger Release".
- 6 If there is another flight of stairs to ascend, follow this step. Pull and turn the machine to approach the first stair of the next flight (see Figure 25). Ensure that the back edge of the Roby is parallel with the stairs. Press the **ascend** pushbutton and rise to the next flight or, if the final destination is reached, release the wheelchair.

Figure 25

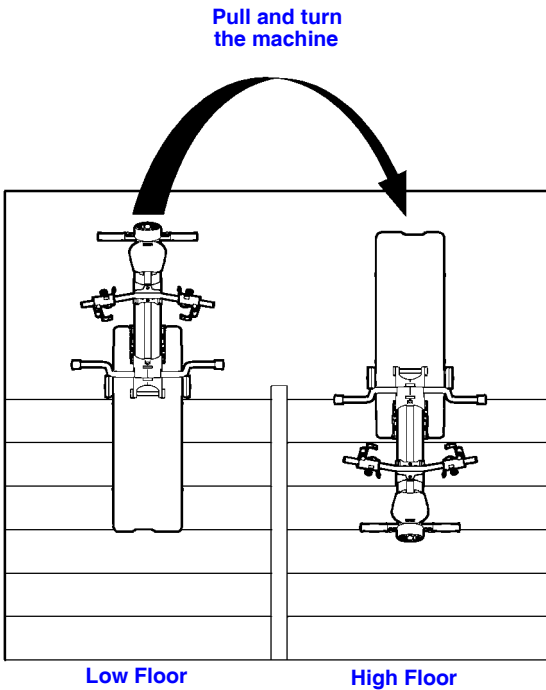

Emergency Stop and Passenger Recovery



In the event of an emergency stop on a flight of stairs, NEVER release the steering bar.

If you lock the Roby, ensure it is stable before releasing your hand grip from the steering bar.

If the stair climber stops during an ascent due to a discharged battery, there may be enough power to descend. Reverse direction to attempt to bring the passenger to a lower level.

If it's not possible to descend to a lower floor, move the machine by using the supplied manual descent lowering handle (Figure 26/a).

Figure 26

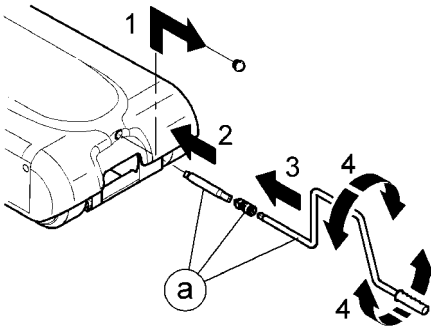

Passenger Release

- 1 At the end of each travel, lift the red plastic safety protective cover (Figure 12/b). Release the red pedal (Figure 13/b) and push the steering bar forward (Figure 13/a) until the wheelchair touches the floor.
- 2 Pull up on the safety clamp pistons (Figure 27/a) and swing the red lever (Figure 27/b) outwards. Loosen the safety clamp locking handwheel (Figure 28/a).

Figure 27

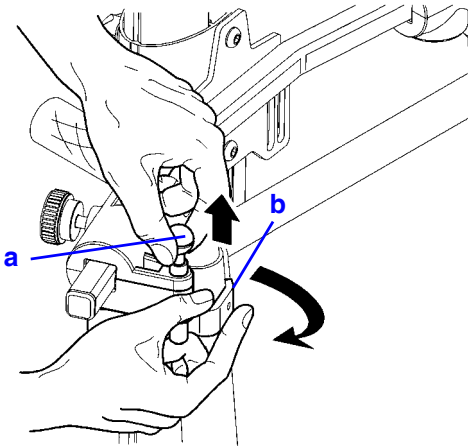
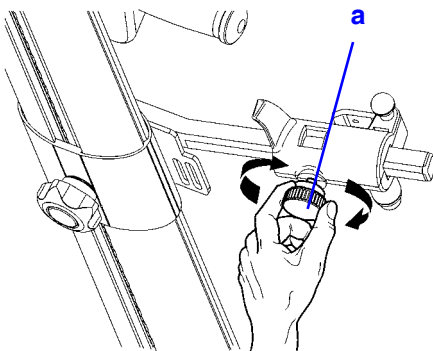

Figure 28



- 3 Lower the steering bar and reattach it to the chassis.
- 4 Move the Roby manually.

7. REVERSING THE SAFETY COUPLINGS

Most wheelchairs include thrust handles (Figure 29/a); however, some wheelchairs are equipped with a horizontal bar on the rear part on the seat back (Figure 30/a).

Figure 29

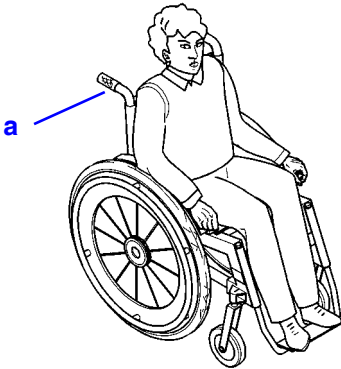
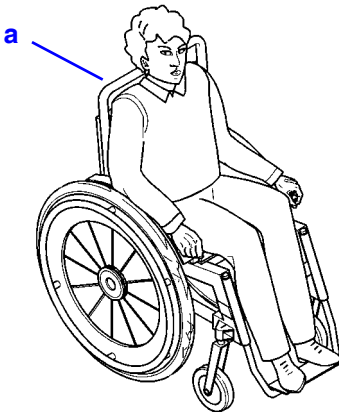

Figure 30



When a horizontal bar is used, rotate the safety clamp assembly (Figure 31/a) (which is equipped with a second hole - Figure 31/b) 90° so that the red hook (Figure 31/c) grasps the horizontal bar from downwards and not laterally. This clamps the wheelchair to the steering bar with the same safety of traditional wheelchairs.

Follow these steps to attach a wheelchair equipped with a horizontal bar to the Roby:

- 1 Remove the setscrew located at each end of the crossbar (Figure 31/d) and loosen the locking handwheel (Figure 31/e).

Figure 31

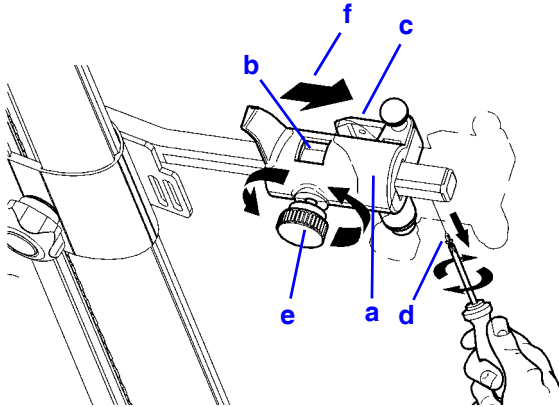

- 2 Extract the safety clamp (Figure 31/a) toward the outside (Figure 13/f).
- 3 Rotate the safety clamp (Figure 32/a) 90° (Figure 32/b) to the left for the left-side clamp and to the right for the right-side clamp.

Figure 32

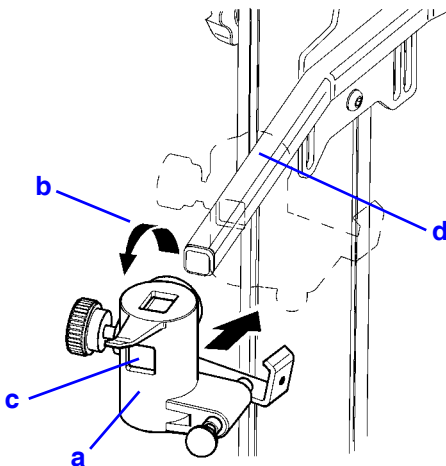

- 4 Orient the hole (Figure 32/c) in the rotated safety clamp with the crossbar (Figure 32/d) and slide the clamp onto the crossbar. Tighten the setscrew located at each end of the crossbar.
- 5 Adjust the crossbar (Figure 33/a) to the wheelchair seat back (Figure 33/b). Pull the safety clamp piston (Figure 33/c), hook the horizontal bar (Figure 33/d) using the hook (Figure 33/e) and release the safety clamp piston (Figure 33/c).

NOTE

Ensure that the piston (Figure 33/c) is placed under the red hook (Figure 33/e) such that it can't be released from the wheelchair (Figure 33/d).

Figure 33

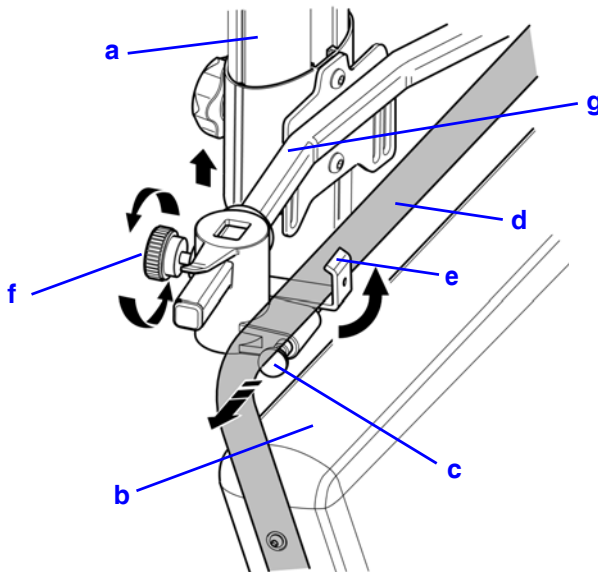

- 6 Lock the safety clamp assembly by turning the handwheel (Figure 33/f).
- 7 Lift the crossbar (Figure 33/g) until the point at which the red hook (Figure 33/e) is placed in contact with the horizontal bar (Figure 33/d) is reached.

8. MAINTENANCE

The Roby maintenance schedule is listed in the table below.

Competence Level Required: O - Trained Operator

MAINTENANCE SCHEDULE	
Component	Frequency
Rubber tracks	Monthly
Wheelchair safety clamp assembly	Monthly
Wheelchair crossbar clamp	Monthly
Steering bar connector	Monthly
Battery and battery charger	Monthly
Electrical wiring	Monthly
Signals	Before every use
Emergency STOP button	Before every use

Perform the following inspections and tests for the components listed in the table above.

- 1 Inspect the tracks to ensure they are not worn and do not include marks, cuts, or excessively worn small blocks.
- 2 Check the wheelchair safety clamp assembly, wheelchair crossbar clamp, and steering bar connector. Ensure these assemblies are intact and in working order.
- 3 The batteries are sealed and are maintenance free. Keep them charged at all times. Use the supplied electrical cable and plug it into a suitable electrical socket.
- 4 Check that the battery charger pilot light indicator is active.
- 5 Check the electrical wiring. Ensure it is not frayed and in need of replacement.
- 6 Check that the emergency STOP is active. Push the emergency STOP button; the controls deactivate. Reset the button by pulling it out.

If any component fails an inspection test, contact your Authorized Dealer.

Maintenance Record

Date	Time	Reason for Call	Comments	Dealer

Periodic Cleaning

Competence Level Required: O - Trained Operator

Frequency: Quarterly



Turn off all power before disassembling any electrical component.

Clean the following external and internal areas to ensure reliable operation:

- 1** Remove the key and the power cable and shut off the power.
- 2** Unscrew the cover screws and remove the cover.
- 3** Clean all dust, dirt, and any accumulated grease.
- 4** Once complete, reconnect the general connector and reassemble the cover.

Charging the Battery

For every seven or eight partial battery charges, at least one charge should be a complete battery charge (until the LED displays green - after about 11 hours of charge). A complete charge helps prolong battery life.

To charge the battery:

- 1 Connect the plug to the Roby (Figure 34).
- 2 Connect the other end to a suitable wall outlet.
- 3 The LED will be orange while the battery is charging. Wait until the LED is green before unplugging the charger.
- 4 Unplug the charger from the wall outlet and from the Roby.
- 5 Use the Roby as per the instructions in this manual.



Do not use the Roby while the battery is charging.

Figure 34

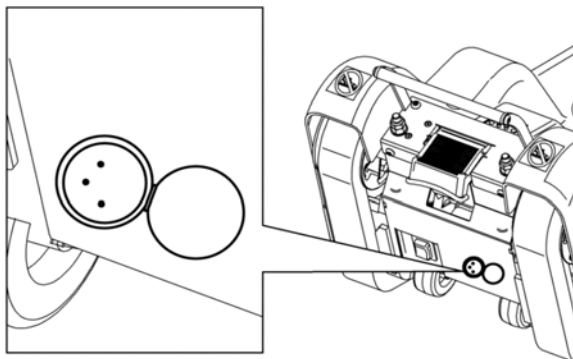

Unit Does Not Start or Move

The following table lists possible causes and solutions in the event that the Roby does not start or move.

If the malfunction persists, contact your Authorized Dealer.

Competence Level Required: O - Trained Operator

Possible causes	Possible solutions
Starting key not inserted	Insert the ON/OFF key
Emergency STOP button pushed in	Pull the emergency STOP button out
Discharged battery	Recharge the battery
Battery discharges immediately after charging	Replace the battery
Safety protective cover not locked down	Lock down safety protective cover

Disposal of Parts and Materials

Rubber and Plastic Materials Disposal

Place all materials for disposal in clean containers and transfer them to authorized centres for salvage and disposal according to the laws and rules in your area.

Run-Down Battery Disposal

Take all used batteries to local depots that are certified for safe battery disposal.

9. DETAILED DRAWINGS

Figures 35 and 36 provided detailed drawings of the Roby.

Figure 35

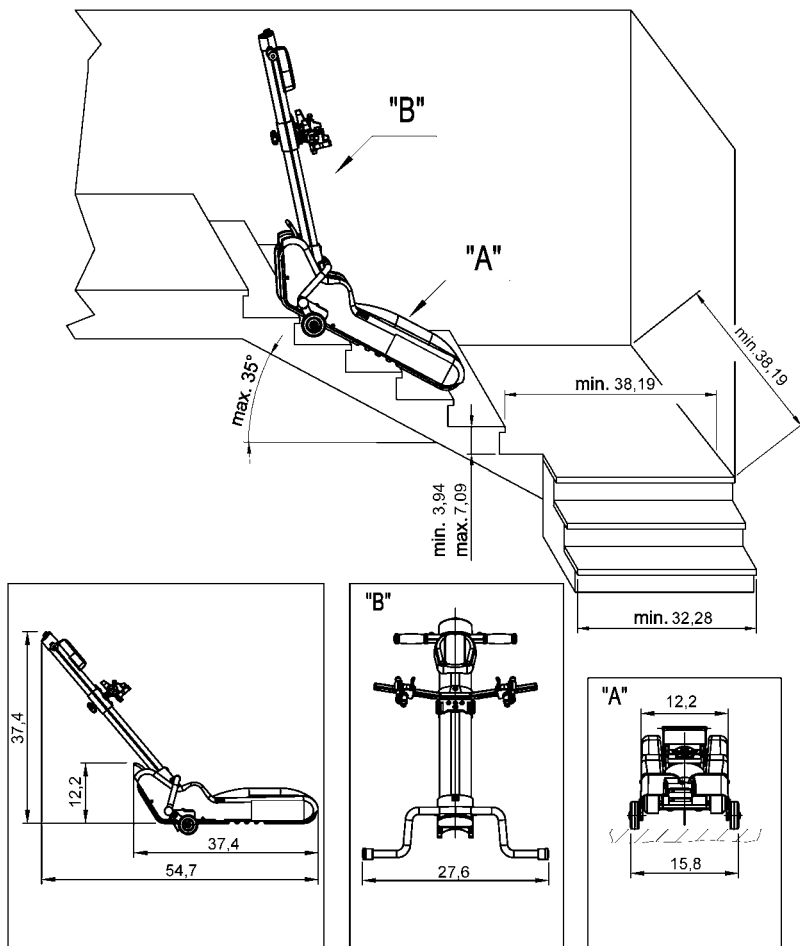
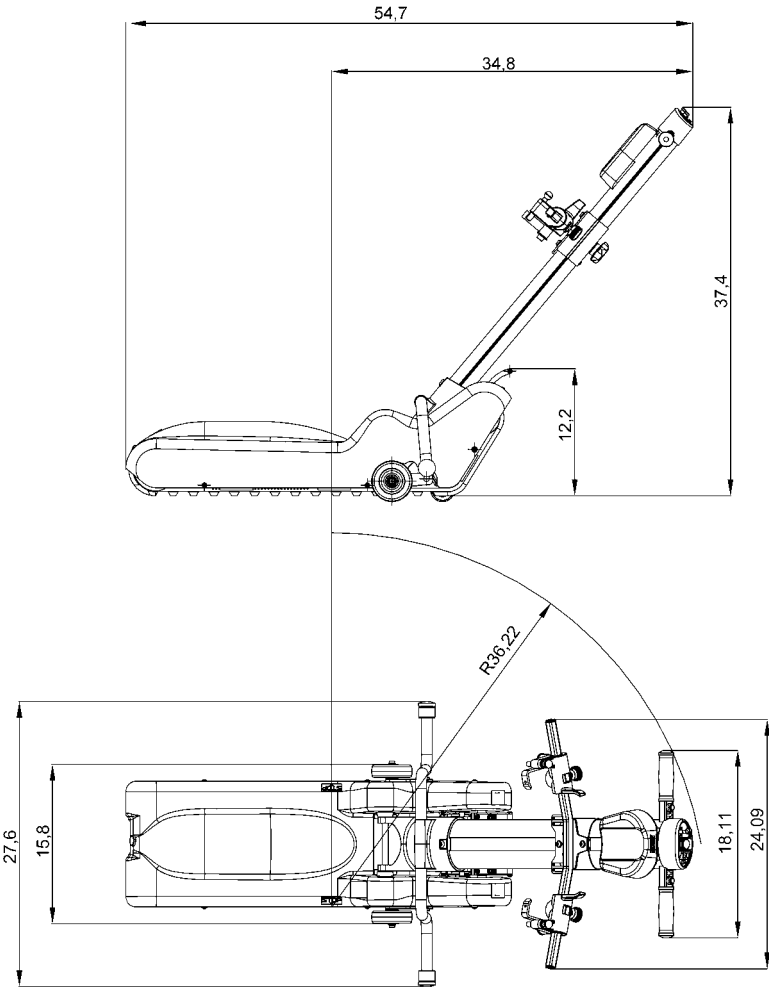

Figure 36



Authorized Savaria Dealer

Roby Powered Stair Climber OWNER'S MANUAL

Part No. 000686
Copyright © 2011

Savaria Corporation
Elevators and Lifts
www.savaria.com

2 Walker Drive
Brampton, Ontario, L6T 5E1, Canada
Tel: (905) 791-5555
Fax: (905) 791-2222
Toll Free: 1-800-661-5112

